

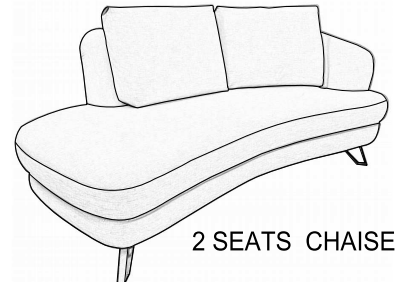

## MH 4184 - 3 Seats and 2 Seats Chaise

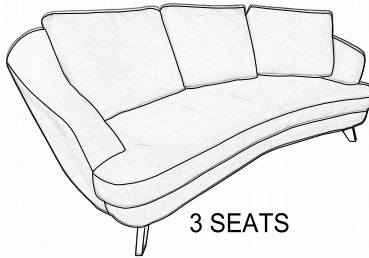
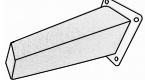
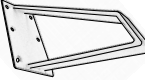

| REF.     | DESCRIPTION   | AMOUNT    |
|----------|---|-----------|
| <b>A</b> |  <b>* Wood foot</b><br>(OPTION)  | <b>4</b>  |
| <b>B</b> |  <b>* Metal foot</b><br>(OPTION) | <b>4</b>  |
| <b>C</b> |  <b>* Screw 5,0 x 40 mm</b>      | <b>16</b> |
| <b>D</b> |  <b>* Carpet kit</b>             | <b>4</b>  |

\* 1° STEP: Turn the sofa over a flat surface, using the packaging as a protection. (fig. 1);

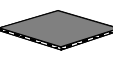
\* 2° STEP: At the bottom, fix the feet according to factory DEFAULT MARKINGS;

\* 3° STEP: Mount the feet as illustrated in figures in figures 1 and 2 according to the choice of feet: wood or metal;

\* 4° STEP: Tighten the screws until the feet are firm;

\* 5° STEP: Glue the carpets (D), to the feet.

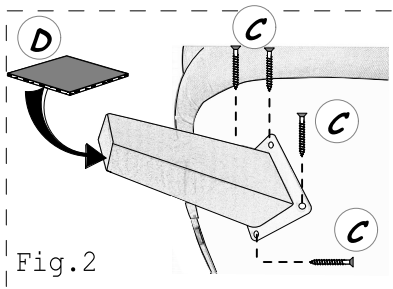
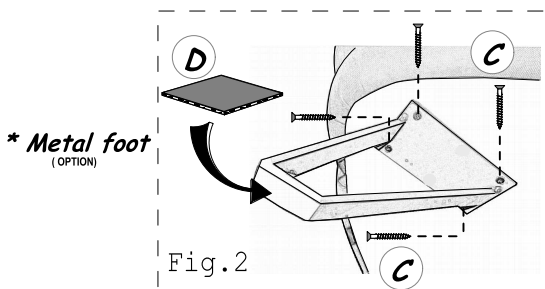

PS.: feet facing out

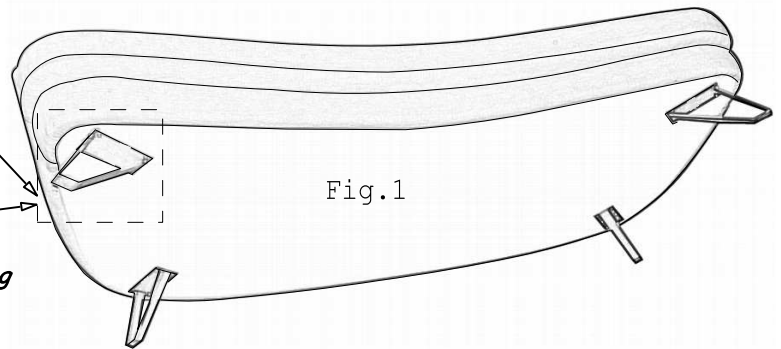

### Handling care:



# Never move the upholstery holding by the lining;

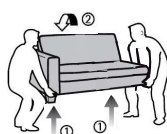

# Move between 2 people;

# To move it, first raise the sofa and only then rotate it.

Assistance  
(51)  
**3564-8382**  
contato@uultis.com  
www.uultis.com

\* IMAGE MERELY ILLUSTRATIVE.

### CONSUMER GUIDELINES :



Do not use chemical, abrasive or steam cleaning products. Avoid contact with sharp objects and prolonged sun exposure;



Fabric: vacuum cleaner or soft bristle brush;  
Feet: cloth slightly moistened with water, followed by dry cloth;



Tool required: not provided;

Screwdriver



People required for product assembly.