

Mesa de centro / Center table / Mesa de centro

MH-9155 EXP

Montagem

Recomenda-se a leitura prévia das instruções de montagem e profissionais especializados para montar.

Assistência

Caso ocorra problema com algum dos componentes, sublinhe-o, identifique o problema e retorne esta relação, via fax ou meio de comunicação disponível para o representante.

 Assinatura do cliente

Assembly

Before the assembling is recommended to read carefully the assembly instruction by professional assemblers.

Assistance

If happen problems with any component, underline the same, identify the problem and send back this relation immediately, by fax or other way.

 Client signature

Montaje

Se recomienda la lectura previa de las instrucciones de montaje y profesionales especializados para montarlos.

Asistencia

Caso sucedan problemas con alguno de los componentes, subraye el componente, identifique el problema, y retorne esta copia via fax u otro medio de comunicación posible.

 Assinatura del cliente

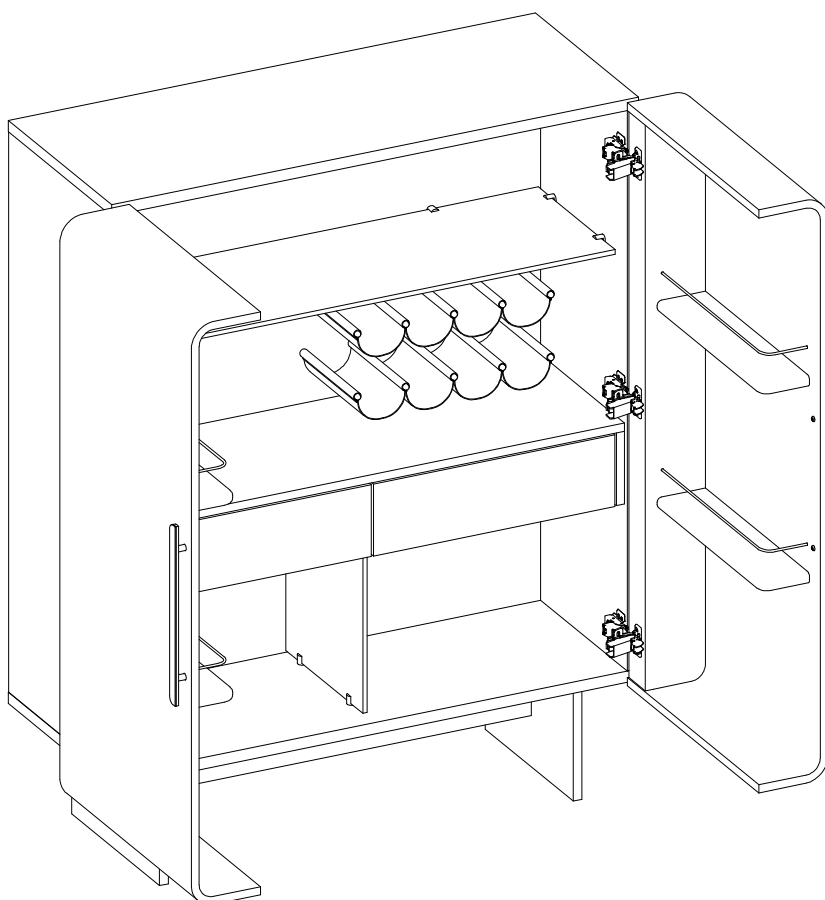

Atenção / Attention / Atención

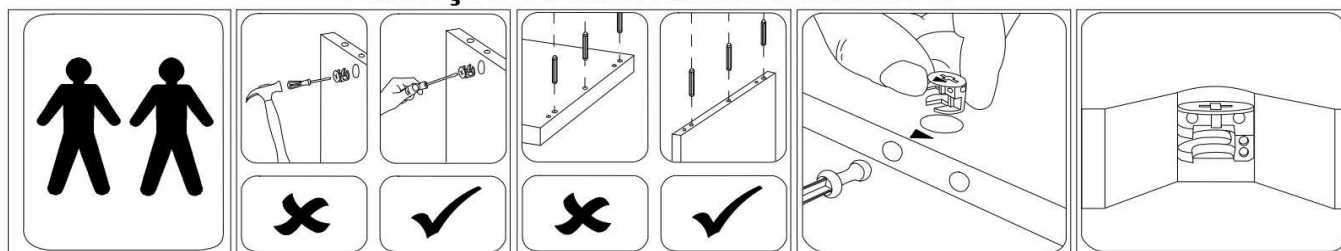

A Uultis se reserva o direito de efetuar alterações nos produtos de suas linhas sem aviso prévio, quando entender necessário.

Uultis reserves the right to effect modifications in the products, without previous advice, when understand necessary.

Uultis se reserva el derecho de hacer las modificaciones que juzgue necesarias en sus productos, sin aviso previo, cuando lo crea necesario.

Assistência Uultis
(51) 3564-8382

MH-9155 EXP

RELAÇÃO DE COMPONENTES / PARTS LIST / LISTA DE COMPONENTES

VOLUME 1

LETRA	LÂMINADO	PEÇA	PART	PIEZA	MED/MEASURE/MED	QTDE
-	K071999	KIT ACESSÓRIOS	ACCESSORY KIT	KIT DE ACCESORIOS	xx	1
F	6177443	CAIXARIA	CASHIER	CARPINTERÍA	xx	1
T	6175918	PUXADOR	HANDLE	TIRADOR	xx	2

VOLUME 2

LETRA	LÂMINADO	PEÇA	PART	PIEZA	MED/MEASURE/MED	QTDE
Y	6175954	BASE DE ACRÍLICO 960X250X20MM C/DES	ACRYLIC BASE 960X250X20MM WITH DESIGN	BASE DE ACRÍLICO 960X250X20MM C/DES	xx	1

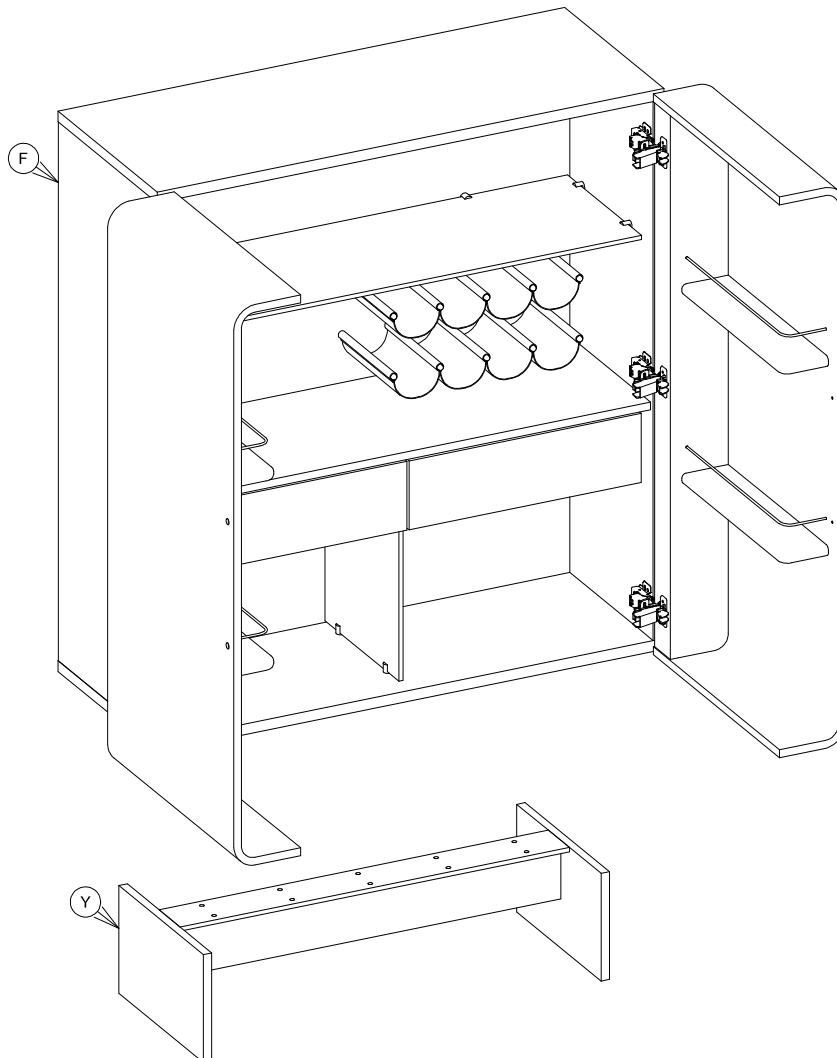

RELAÇÃO DE COMPONENTES / PARTS LIST / LISTA DE COMPONENTES

CÓDIGO DO KIT: **K071999**

KIT

REF.	QTDE	PEÇA	PART	PIEZA	IMAGE
11.c	2	PARAFUSO 4.5 X 16 CAB.FLANGEADO	SCREW 4.5 X 16MM	TORNILLO 4.5 X 16MM	
19.c	2	PARAFUSO 5 X 50 CAB.FLANGEADO	SCREW 5 X 50MM	TORNILLO 5 X 50MM	
3.q	2	ARRUELA LISA 1/4 X 17X1,2 REDONDA ZINCADA ZB	WASHER FLAT 1/4x17x1,2MM ROUND	ANILLO PLANA 1/4x17x1,2MM RONDA	
9.r	2	BUCHA FISCHER 8 x 50 DRAIOL	8 x 50 PLUG	TARUGO 8 x 50	
CS	1	CINTA DE SEGURANÇA	SEAT BELT	CINTURÓN DE SEGURIDAD	
EN	1	ENGATE REF 14537	COUPLING REF 14537	ENGANCHE REF 14537	
SA	1	SUPORTE ALÇA C/PARAF 035639.000.020B	HANDLE SUPPORT W/SCREW 035639.000.020B	SOPORTE ASA C/PERNO 035639.000.020B	
1.g	1	CHAVEZETA ALLEM 4MM	4MM KEY	CLAVE 4MM	
30.e	6	PARAFUSO 1-4X25 CAB 13MM ALLEN	SCREW 1-4X25 HED 13MM ALLEM	TORNILLO 1-4X25 DE CABEZA 13MM ALLEM	
42.m	4	PARAF. 1/4X1 CAB ABAULADA SEXT. INT	SCREW 1/4X3/4	TORNILLO 1/4X3/4	

MH-9155 EXP

Passo
Step **1**
Paso

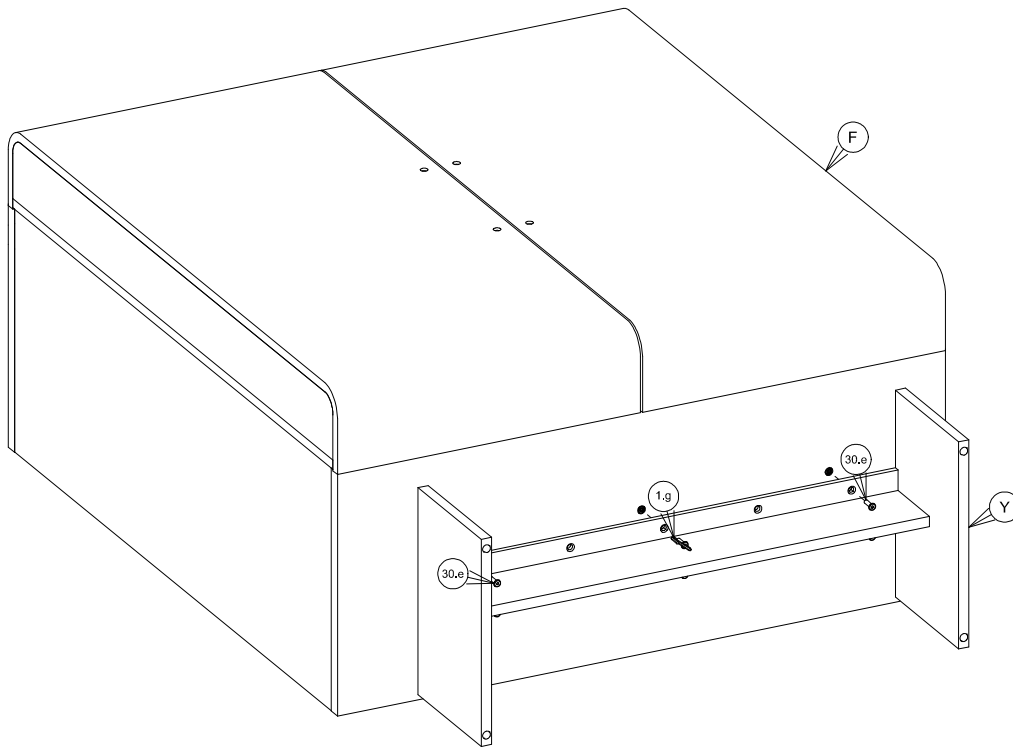

Passo
Step **2**
Paso

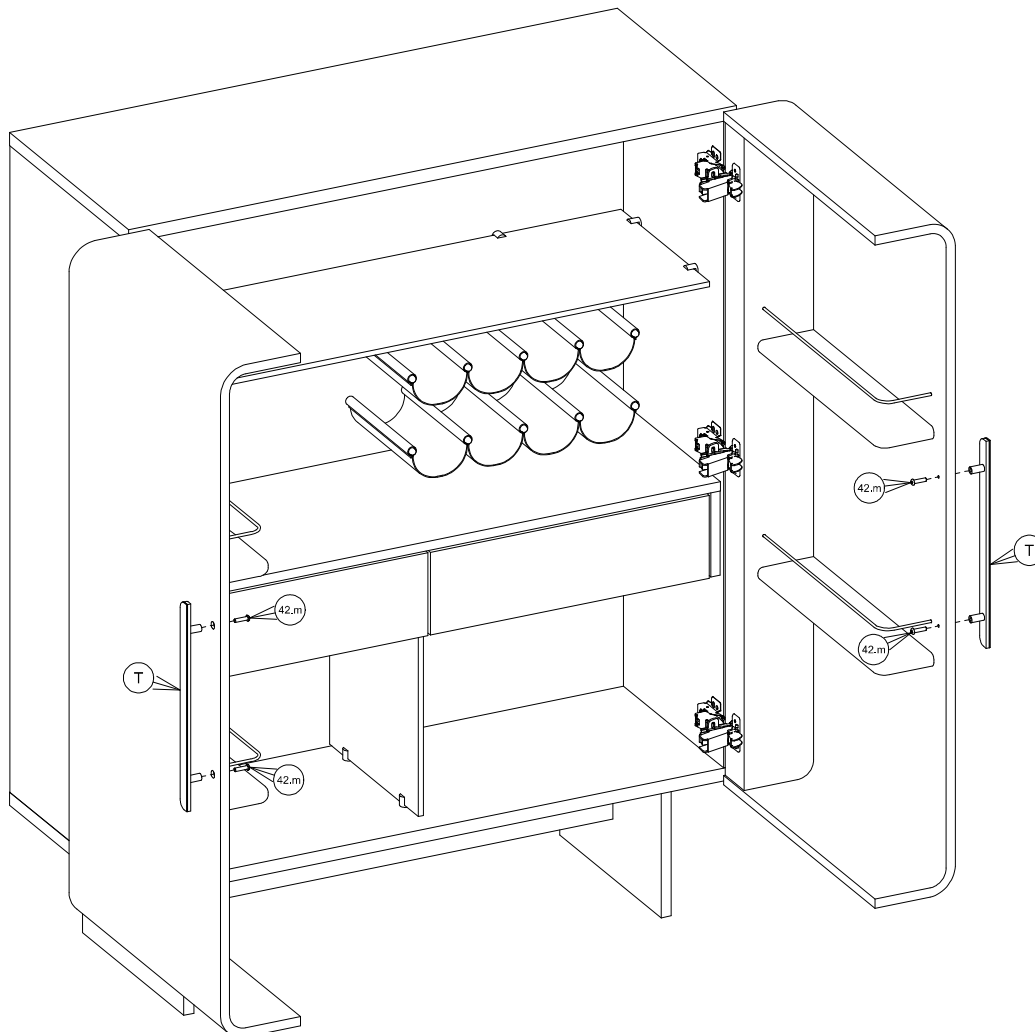

MH-9155 EXP

Passo
Step **3**
Paso

Cada porta suporta aproximadamente 5 kg, não exceder este peso.

Each door supports approximately 5 kg, do not exceed this weight.

Cada puerta soporta aproximadamente 5 kg, no exceda este peso.

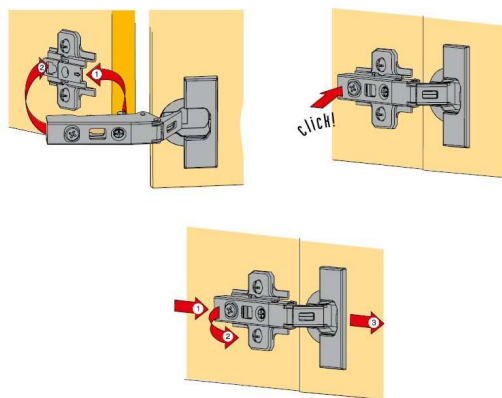
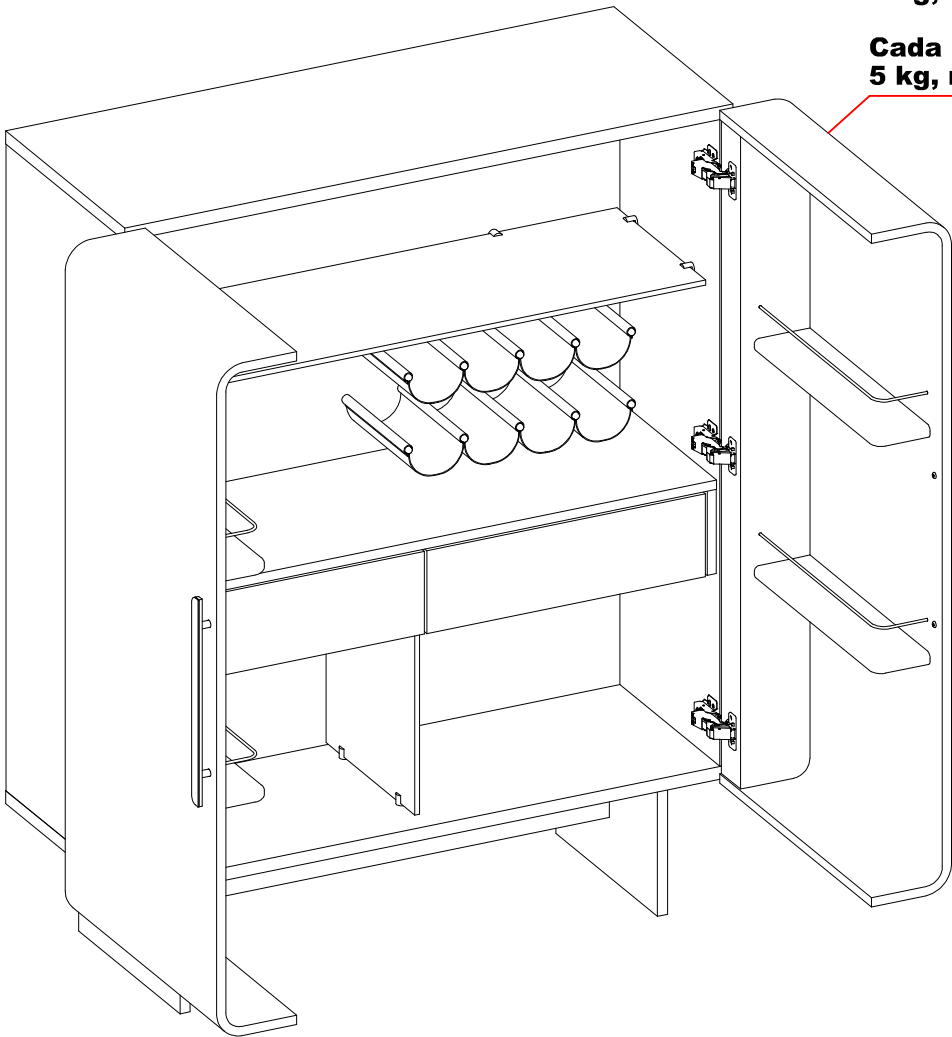

MH-9155 EXP

Passo
Step **4**
Paso

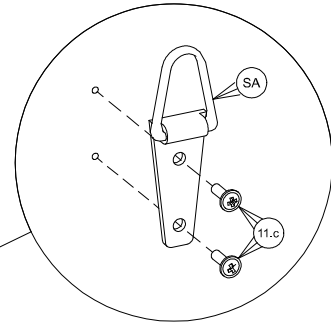
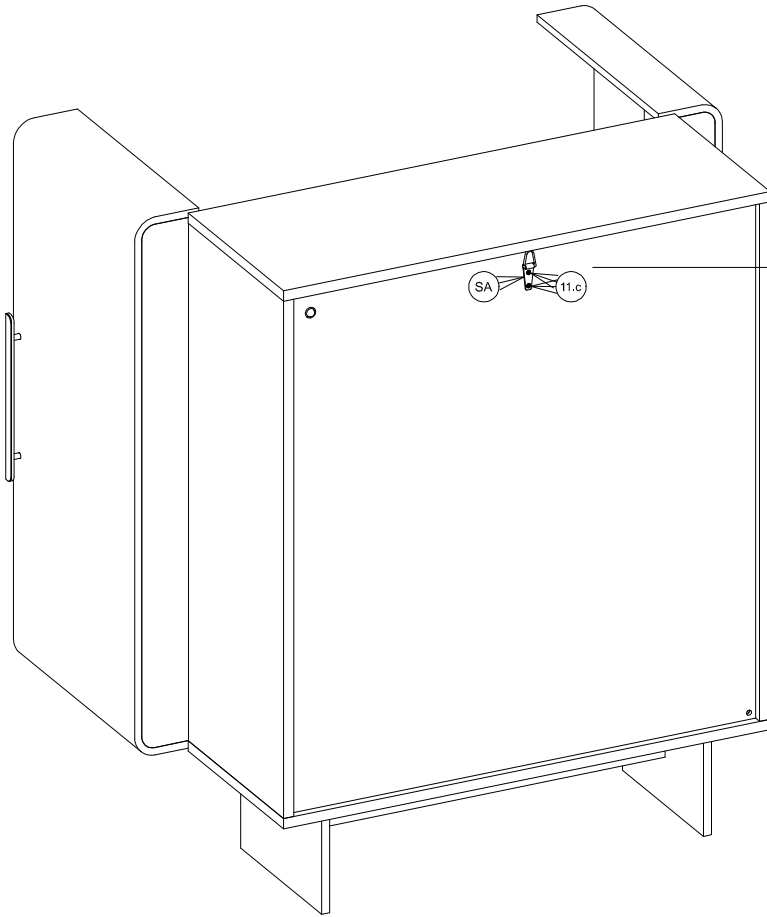

Passo
Step **5**
Paso

Imagem da parede meramente ilustrativa.
Image of the wall is merely illustrative.
Imagen de la pared meramente ilustrativa

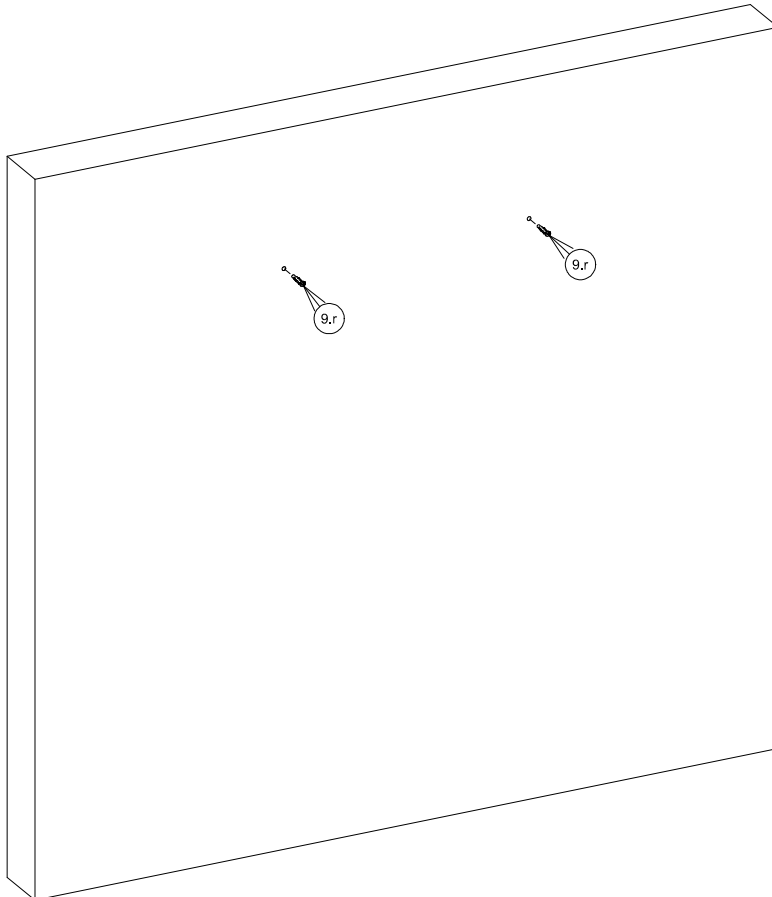

Parede
Wall
Pared

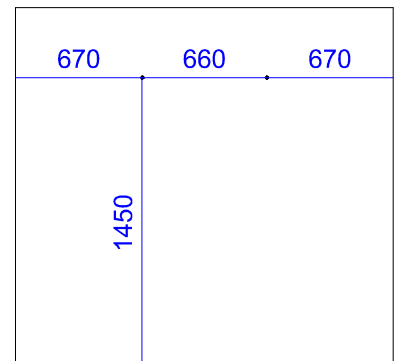

MH-9155 EXP

Passo
Step **6**
Paso

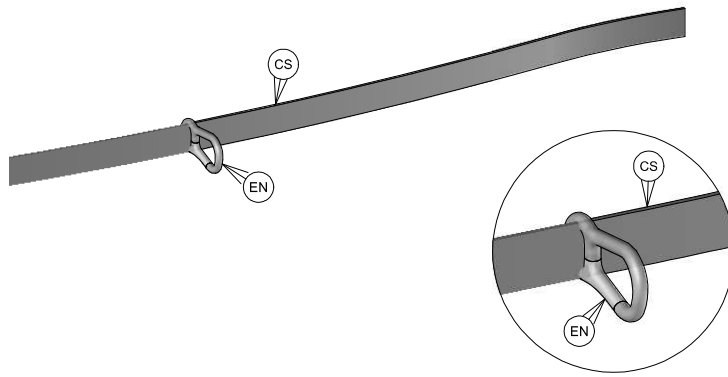

Passa a cinta de segurança pela alça do engate e divide igualmente.
Pass the seatbelt through the hitch loop and distribute it evenly.
Pasa el cinturón de seguridad por la asa del enganche y repártelo por igual.

Passo
Step **7**
Paso

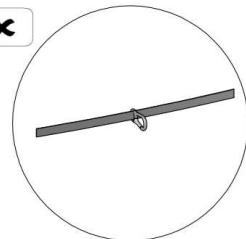
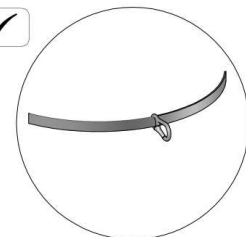
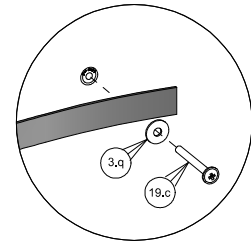
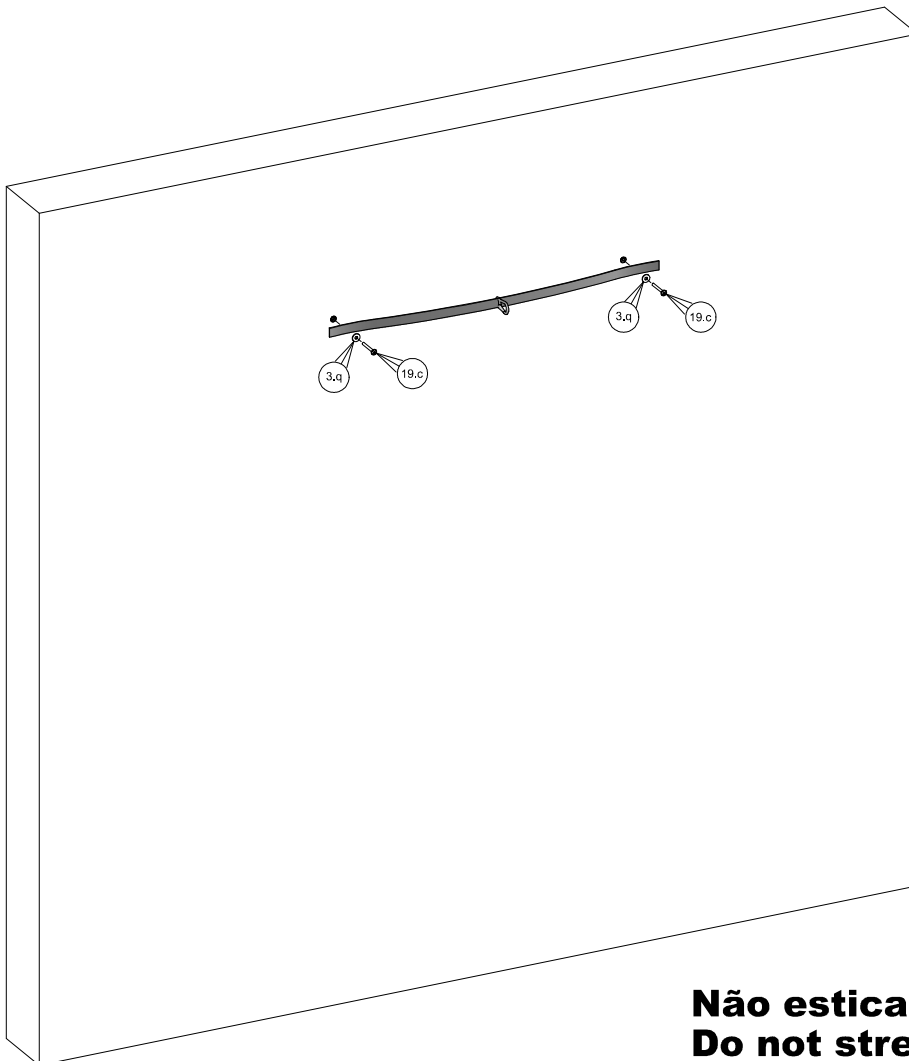

Não esticar a cinta!!
Do not stretch the belt!!
No estirar la cinta!!

MH-9155 EXP

Passo
Step **8**
Paso

